



FARAMA

GÜVENLİĞİNİZ *en üst* NOKTADA

The most secure doors

GÜVENLİĞİNİZ *en üst* NOKTADA
The most secure doors

FARAMA.com.tr

FARAMA.com.tr

YENİLİK *kapıda* BAŞLAR

security doors

FARAMA® olarak “Yenilik Kapıda Başlar” temasıyla hazırladığımız çelik kapı kataloğumuzu sunmaktan mutluluk duyuyoruz.

Güvenliği ve estetiği bir arada sunan tasarımlarımızla, yenilikçi teknolojilerimiz sayesinde, kalitemizi en üst düzeyde tutarak kullanıcı dostu ürünlerimizi sizlerin hizmetine sunuyoruz.

Son teknolojiyi kullanan makine parkurumuzla, üretim sürecimizde çevre dostu ve dayanıklı malzemeleri tercih ediyoruz. Güvenli ve estetik kapılarımızla, evinizde ve işyerinizde rahat ve huzurlu bir yaşamın kapılarını aralıyoruz.

FARAMA®'le birlikte yenilik kapıda başlar.



Security
Doors

İmalatımız size özel tasarlandı...

Günümüz üretim dünyasında artan rekabet ortamı sebebiyle üretim yapan her işletmenin girdi prosesindeki en önemli hedefi uygun kaliteyi en iyi fiyata alabilmek olmuştur. Bu hedefe yönelik hassasiyet ve çaba her geçen gün artmaktadır. Bu hassasiyetin yanında iyi müşteri ilişkileri, güvenilirlik, üretim esnekliği, kapasitesi ve hızı, ürün çeşitliliği, sürekli yenilik gibi etkenlerde tercih sebebi olmaktadır. Bütün bu öne çıkan ayrıcalık ve tercih sebebi olan özellikleri müşterilerimize sunabilmek için iyi bir kalite anlayışı, teknolojik gelişmelere açık, verimlilik odaklı, esnek bir üretim sistemi ve profesyonel çalışanlarla hizmet sunan, müşteri odaklı bir anlayış gereklidir.

FARAMA Çelik Kapı olarak tüm bu gerekliliklerin analizini dikkatle yaparak, iyi fiyat, uygun/aranan kalite, müşteri odaklılık ve sürekli gelişip kurumsallaşmaya hedefleri ile 2007 yılında çıktığımız yola bugün 15.000 metre kapalı alanda, doksan çalışmamız ile devam etmekteyiz. 2023 yılında ürün portföyümüze eklenen yeni modelleri, yine müşterilerimizin bu alandaki ihtiyaçlarına da çözümler sunarak, hizmet vermekteyiz. Temennimiz bu modellerle sektöründe kalıcı olarak ihtiyaçlarınıza hızla cevap verecek, ekonomimize destek sağlayarak büyüyen bir işletme haline gelebilmektir. Çıktığımız bu yolda bizi tercih ederek onurlandıran, siz değerli müşterilerimize teşekkürlerimizi sunarız.

Due to the increasingly competitive environment in today's production world, the most important goal of every manufacturing enterprise in the input process has become to get the appropriate quality at the best price. The sensitivity and effort directed toward this goal are growing by the day. Aside from this sensitivity, factors like good customer relations, dependability, production flexibility, capacity, speed, product variety, and continuous innovation are preferred. To provide all of these prominent benefits and desirable features to our customers, we must have a good understanding of quality, be open to technological developments, have an efficiency-oriented, flexible production system, and a customer-oriented understanding that provides service to professional employees.

At FARAMA Steel Door, we continue our journey that began in 2007 with the goals of affordable price, appropriate, desired quality, customer orientation, and continuous development and institutionalization with ninety employees in a closed area of ten thousand meters today. New models were added to our product portfolio in 2023, and we are assisting our customers by providing solutions to their needs in this field. With these models, we hope to become a growing business that will respond quickly to your needs and support our economy. We'd like to thank you, our valued customers, for honoring us by choosing us on this journey.

Sürdürülebilir Çevre ve Üretim

Firmamız sürdürülebilir bir çevre için, tüm enerji ihtiyacını güneş enerji panellerinden karşılamaktadır.

Bu sayede 1.5 milyon kWh'lık elektrik ihtiyacı, yenilenebilir enerjiden karşılanmaktadır. Böylece 510 bin ağacın azaltılabileceği sera gazı miktarına eş değer karbon emisyonunu engellemiş olacağız.

For a sustainable environment, our company meets all its energy needs from solar energy panels, thus, the electricity needs of 1.5 million kWh are met from renewable energy.

In this way, we will prevent carbon emissions equivalent to the amount of greenhouse gas that 510.000 trees can reduce.

new collec tion

YENİ KOLEKSİYON

13 B E X



PATENTLİDİR
2023/001034

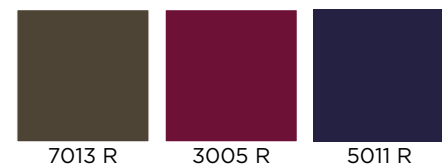



14
B E X



PATENTLİDİR
2023/001034



9018 R

15 B E X

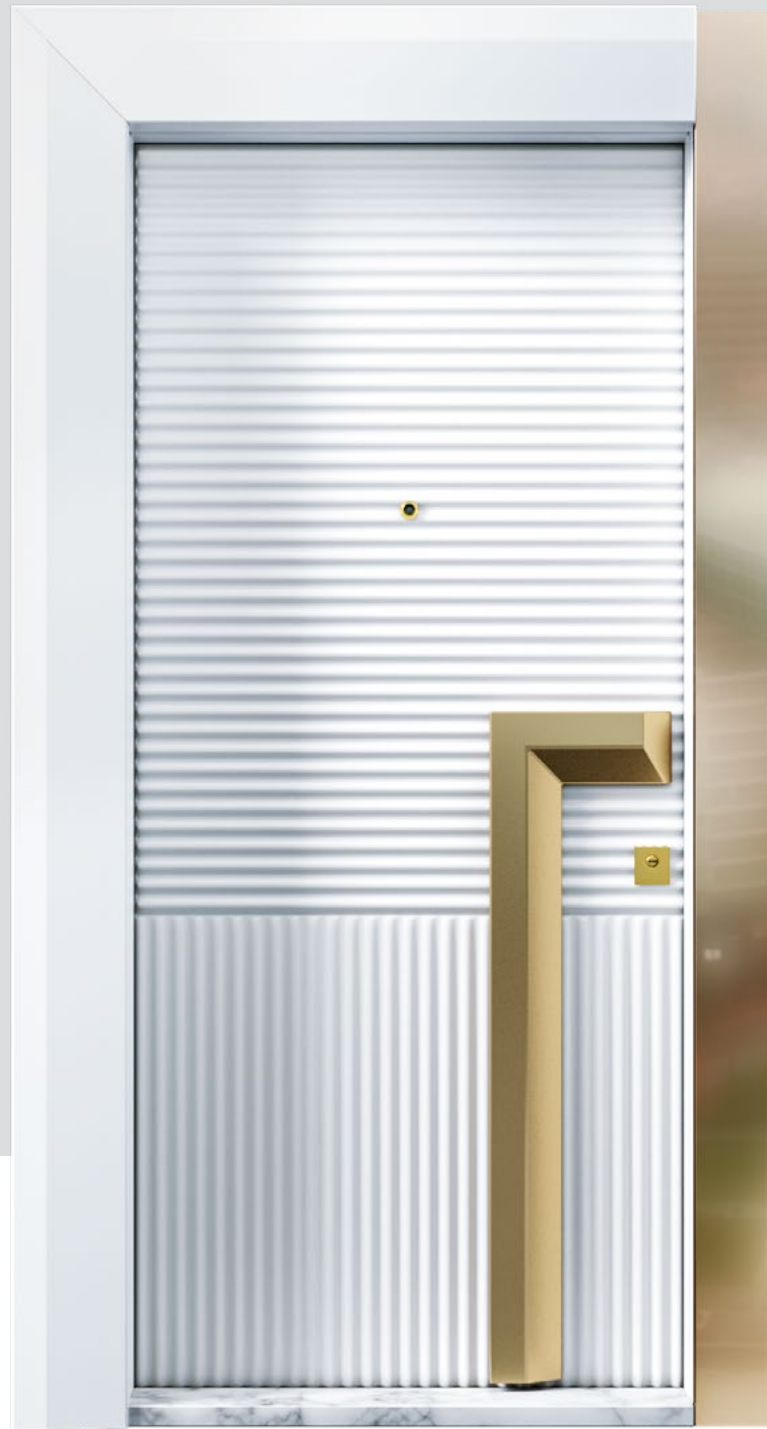

PATENTLİDİR
2023/001034

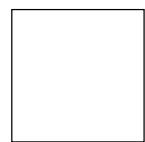

9003 R



9018 R



16

B E X

PATENTLİDİR
2023/001034



17 B E X



PATENTLIDIR
2023/001034

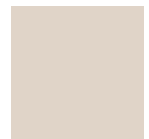

LD 167



18
B E X



PATENTLİDİR
2023/001034

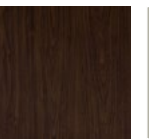

UNL 246



7044 R

19 B E X

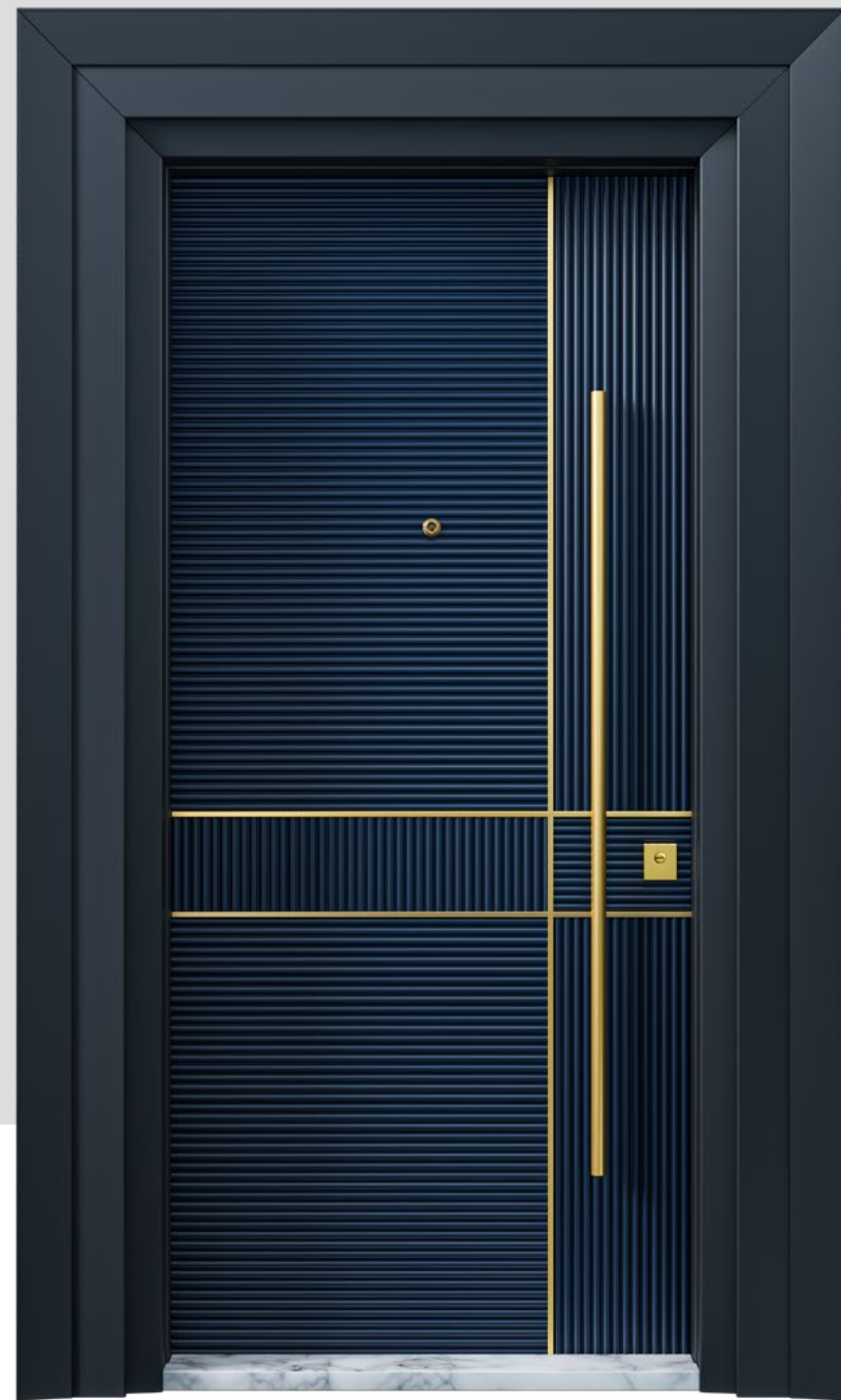

PATENTLIDIR
2023/001034



7036 R



20
B E X

PATENTLİDİR
2023/001034

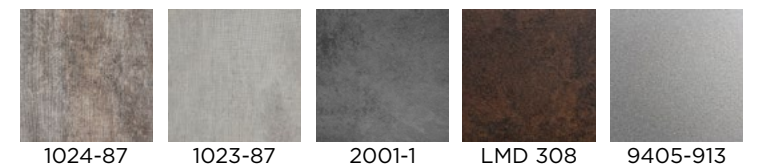

21 B E X



PATENTLİDİR
2023/001034





22

B E X

PATENTLİDİR
2023/001034

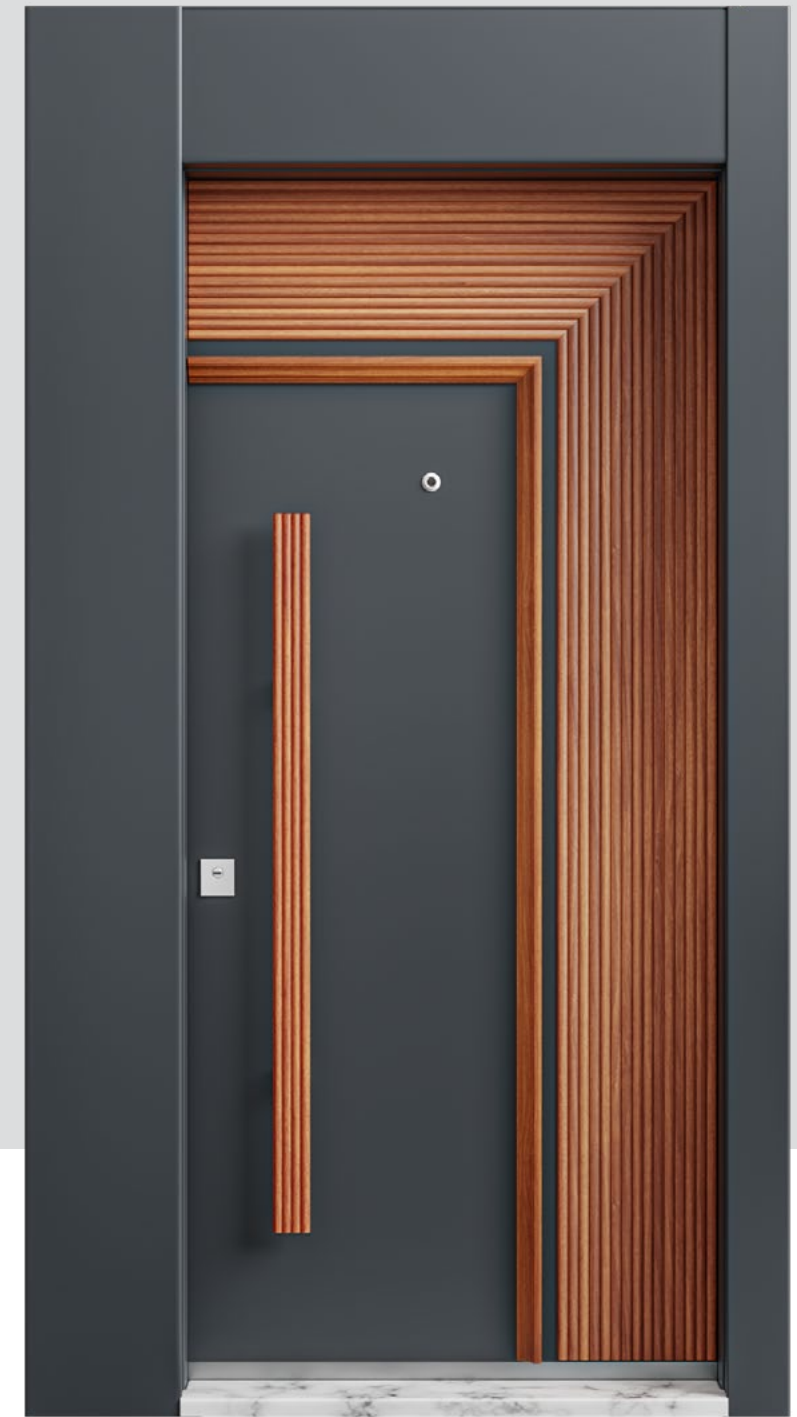

23 B E X



PATENTLİDİR
2023/001034





24
B E X



PATENTLİDİR
2023/001034

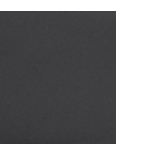

UNL 9007

25 B E X



PATENTLIDIR
2023/001034





26

B E X



PATENTLİDİR
2023/001034



3509-03

27

B E X



PATENTLİDİR
2023/001034

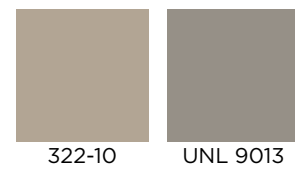



28

B E X



PATENTLİDİR
2023/001034



1019 R

5024 R

LD 147

29 B E X

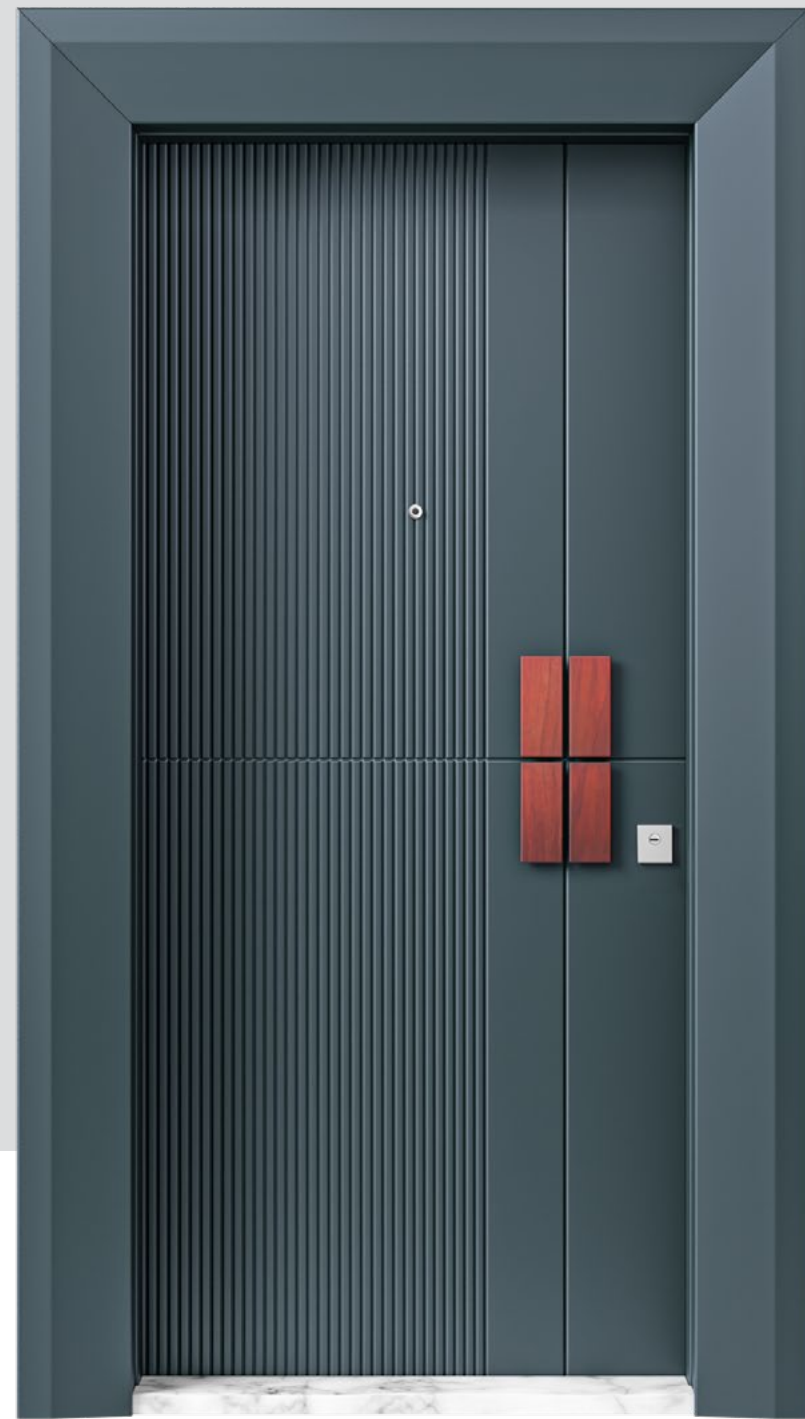

PATENTLİDİR
2023/001034

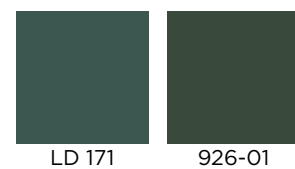



30

B E X



PATENTLİDİR
2023/001034



31 B E X



PATENTLIDIR
2023/001034

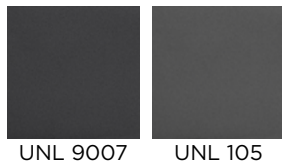

UNL 9007 UNL 105





32

B E X



PATENTLİDİR
2023/001034

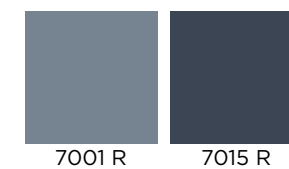

33 B E X



PATENTLİDİR
2023/001034



664-01





34
B E X



PATENTLİDİR
2023/001034



9006 R

35 B E X



PATENTLIDIR
2023/001034

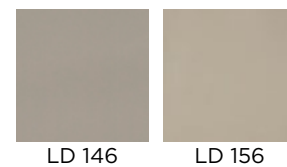



36

B E X



PATENTLİDİR
2023/001034

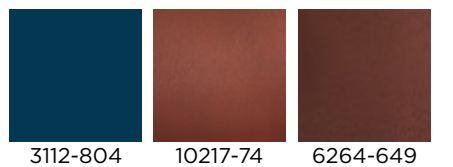

3112-804

10217-74

6264-649

37 B E X



PATENTLIDIR
2023/001034



UNL 101-1

UNL 112





38

B E X



PATENTLİDİR
2023/001034



UNL 9007



UNL 9013

39 B E X



PATENTLIDIR
2023/001034

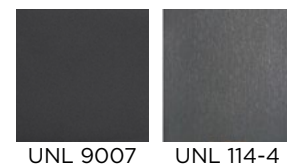



40
B E X

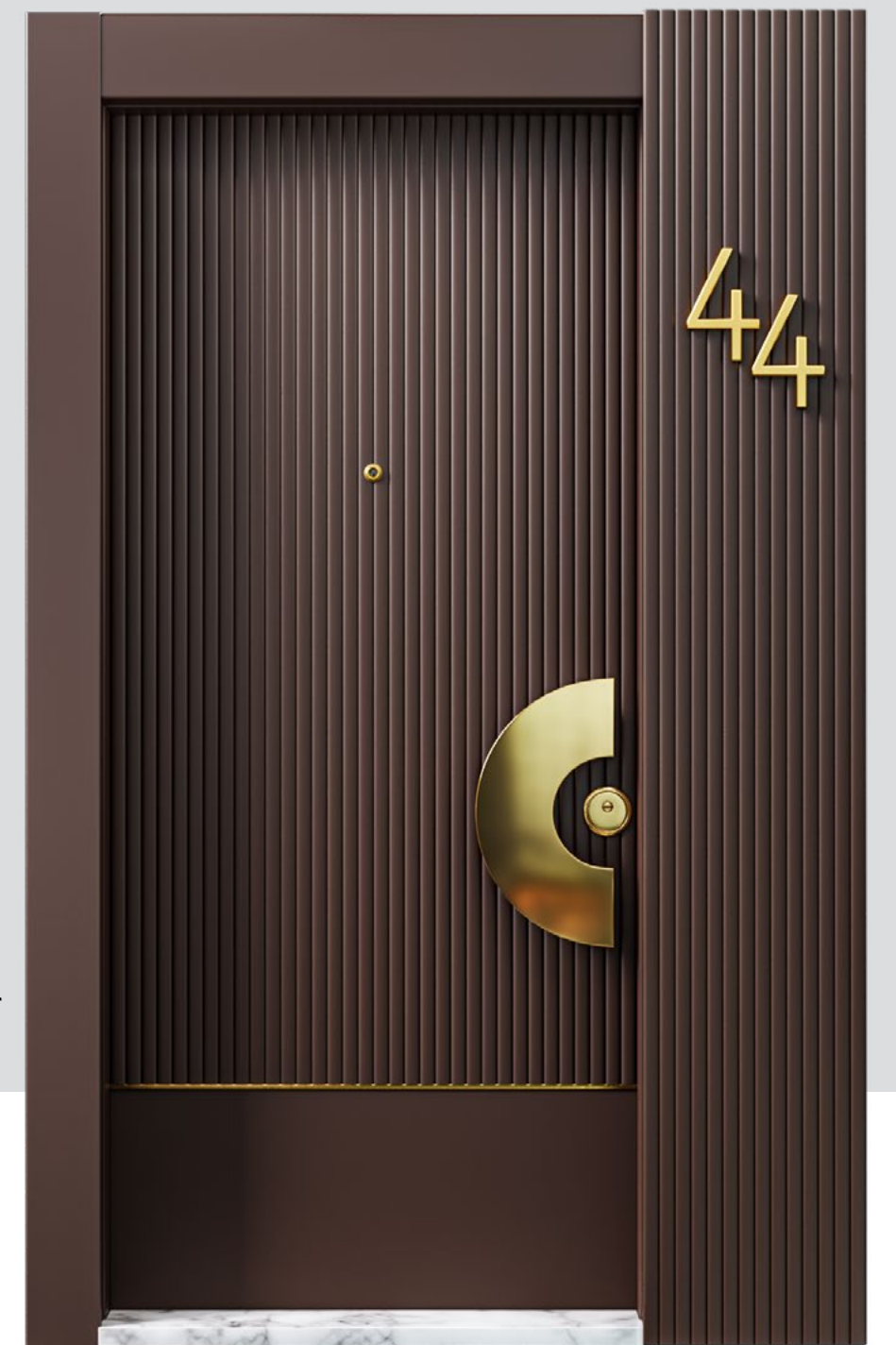

PATENTLİDİR
2023/001034



UNL 9007

41 B E X



PATENTLİDİR
2023/001034



UNL 9003 UNL 9005



42

B E X

PATENTLİDİR
2023/001034

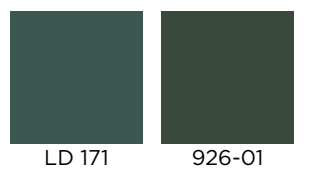

LD 171

926-01

43 B E X



PATENTLİDİR
2023/001034

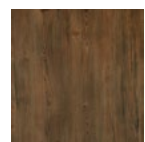

UNL 2048





44
B E X

PATENTLİDİR
2023/001034

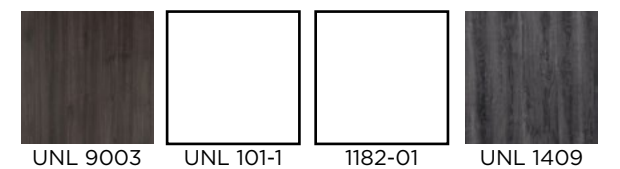

UNL 9003 UNL 101-1 UNL 1182-01 UNL 1409

45 B E X

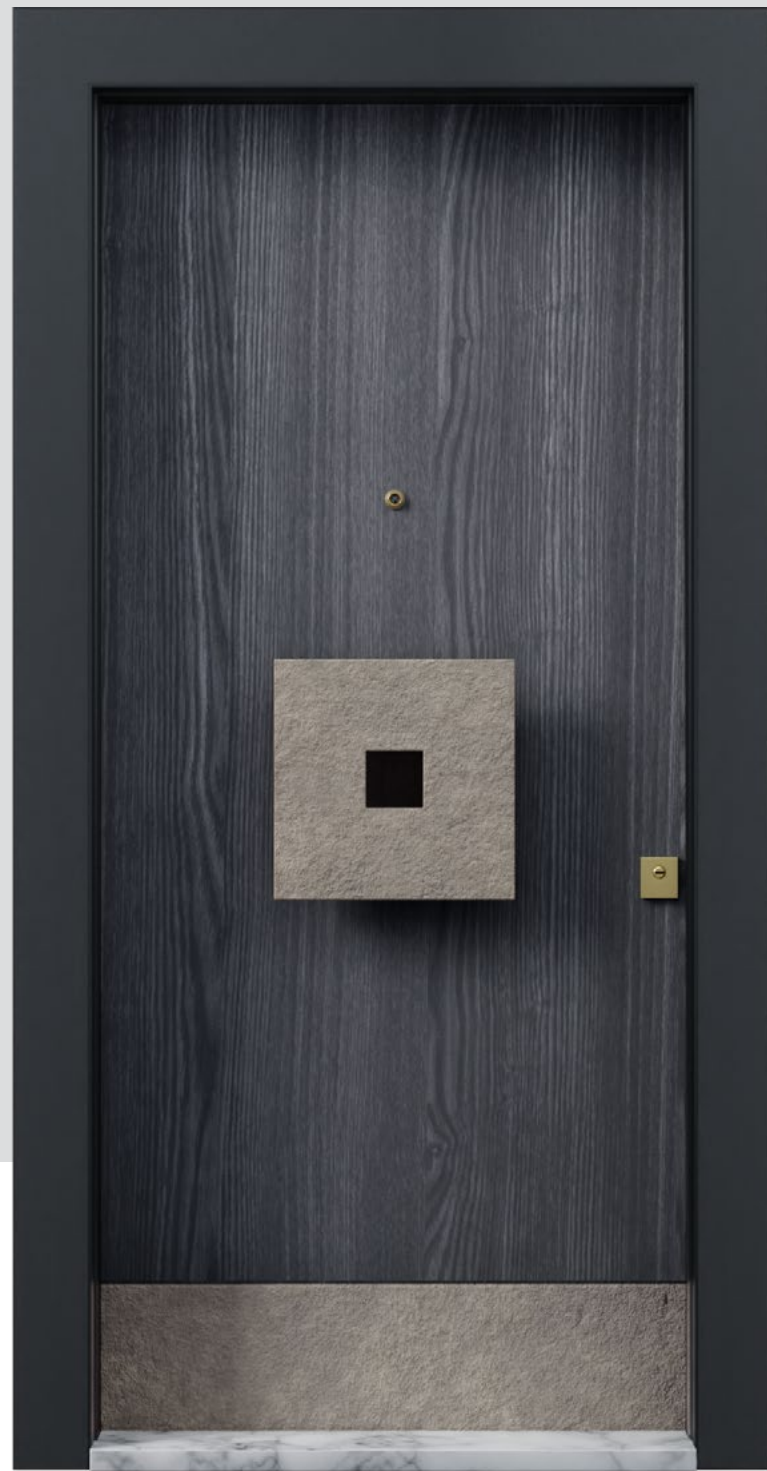

PATENTLIDIR
2023/001034

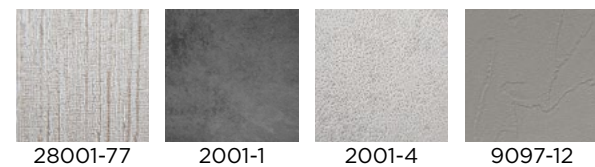



46

B E X



PATENTLİDİR
2023/001034

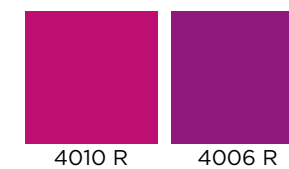

47 B E X



PATENTLİDİR
2023/001034

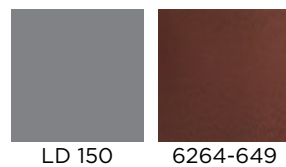



48

B E X



PATENTLİDİR
2023/001034

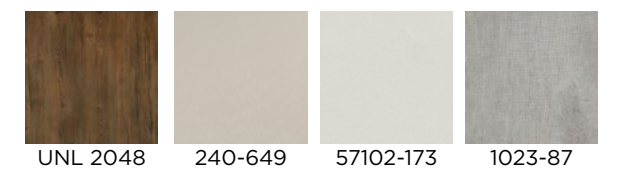



Exclusive Serisi | Exclusive Doors

01 BEX



Exclusive Serisi | Exclusive Doors

02 BEX

11 BTK

Lüks Tabii Kabartma Serisi | Luxury Natural Embossed Doors



12 BTK

Lüks Tabii Kabartma Serisi | Luxury Natural Embossed Doors

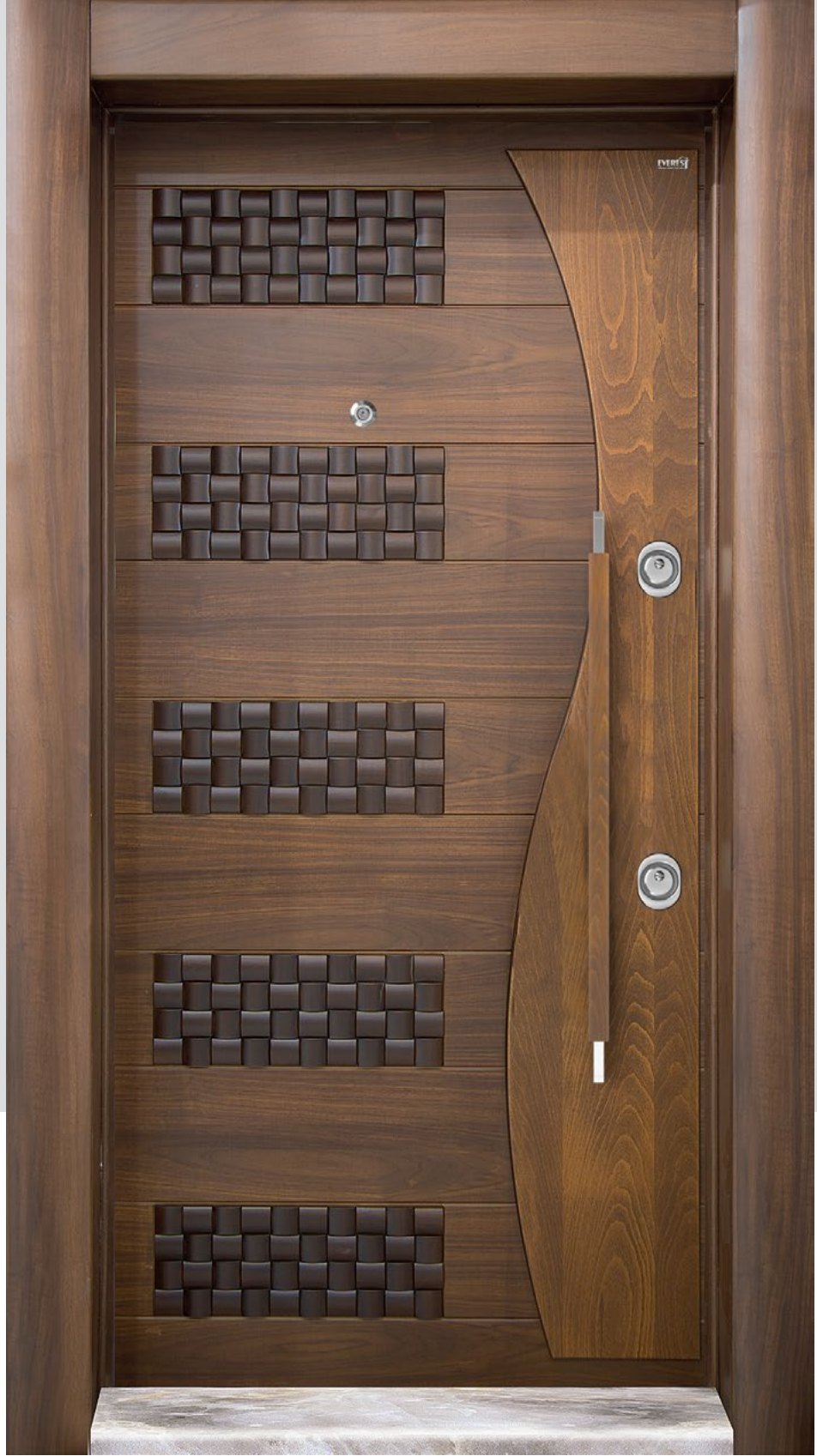
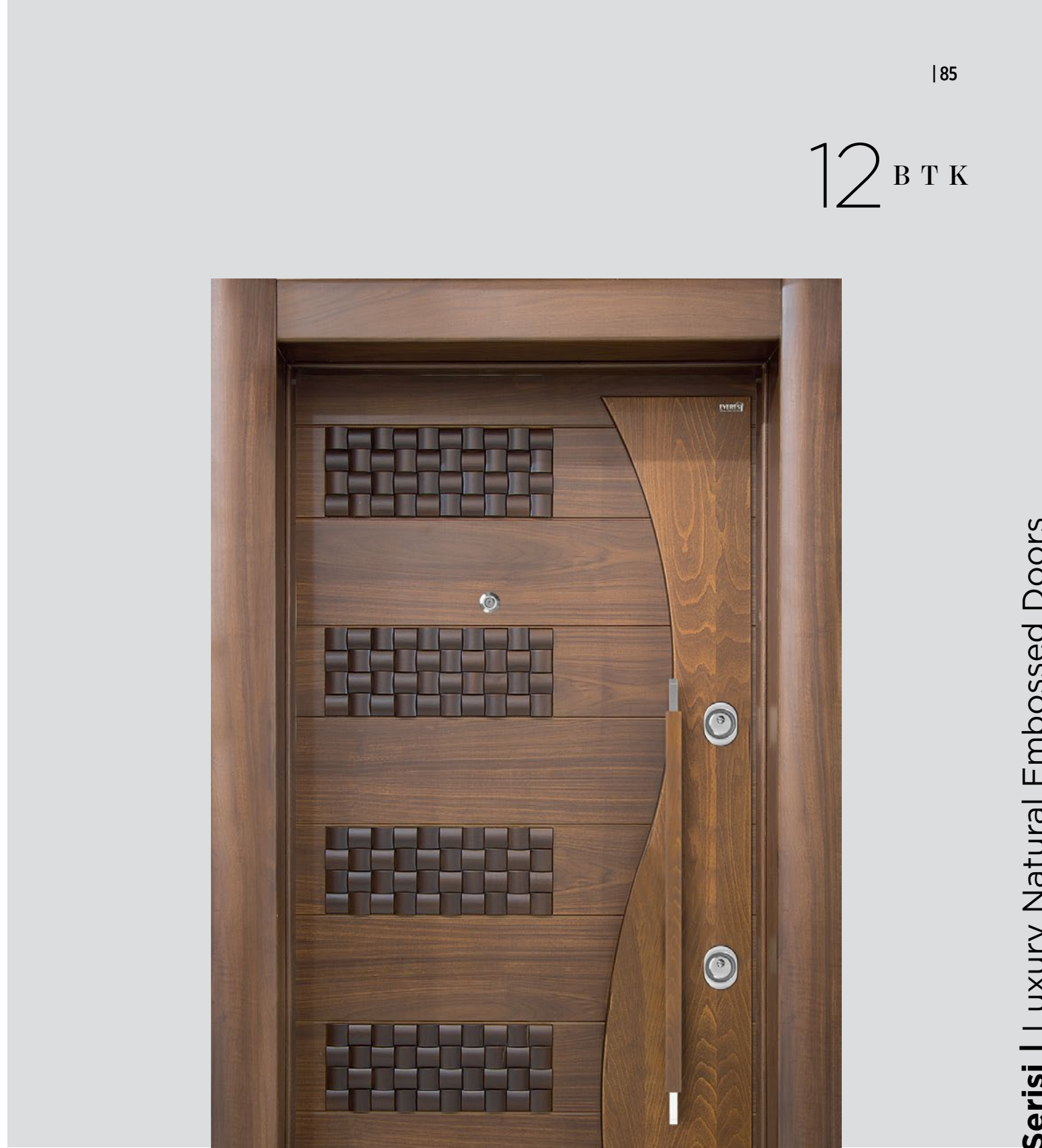

13 BTR



Termo Serisi | Thermo Doors

14 BTR



15 BTR

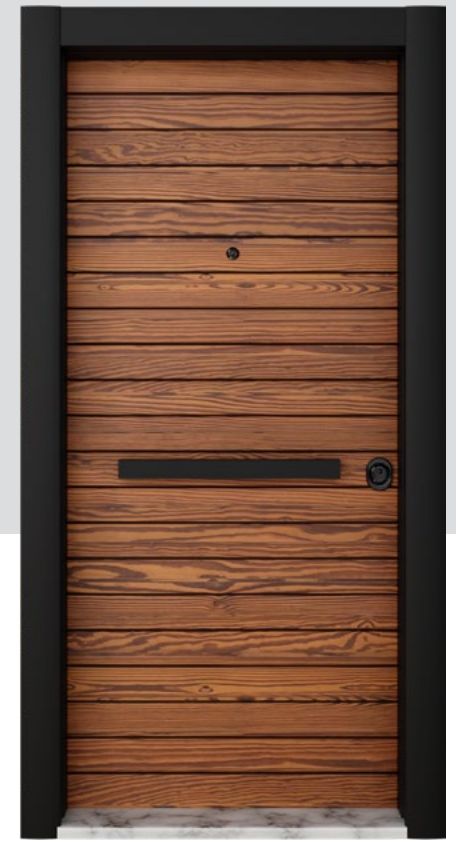

16 BTR



17 BTR



Termo Serisi | Thermo Doors

23 BAK



Alüminyum Kompozit Serisi | Aluminum Composite Doors

24 BAK



28 BAK



29 BAK



30 BAK



Alüminyum Kompozit Serisi | Aluminum Composite Doors



33
BPV



36
BPV



39
BPV



40
BPV

PVC Kabartma Serisi | PVC Embossed Doors

45 BPV

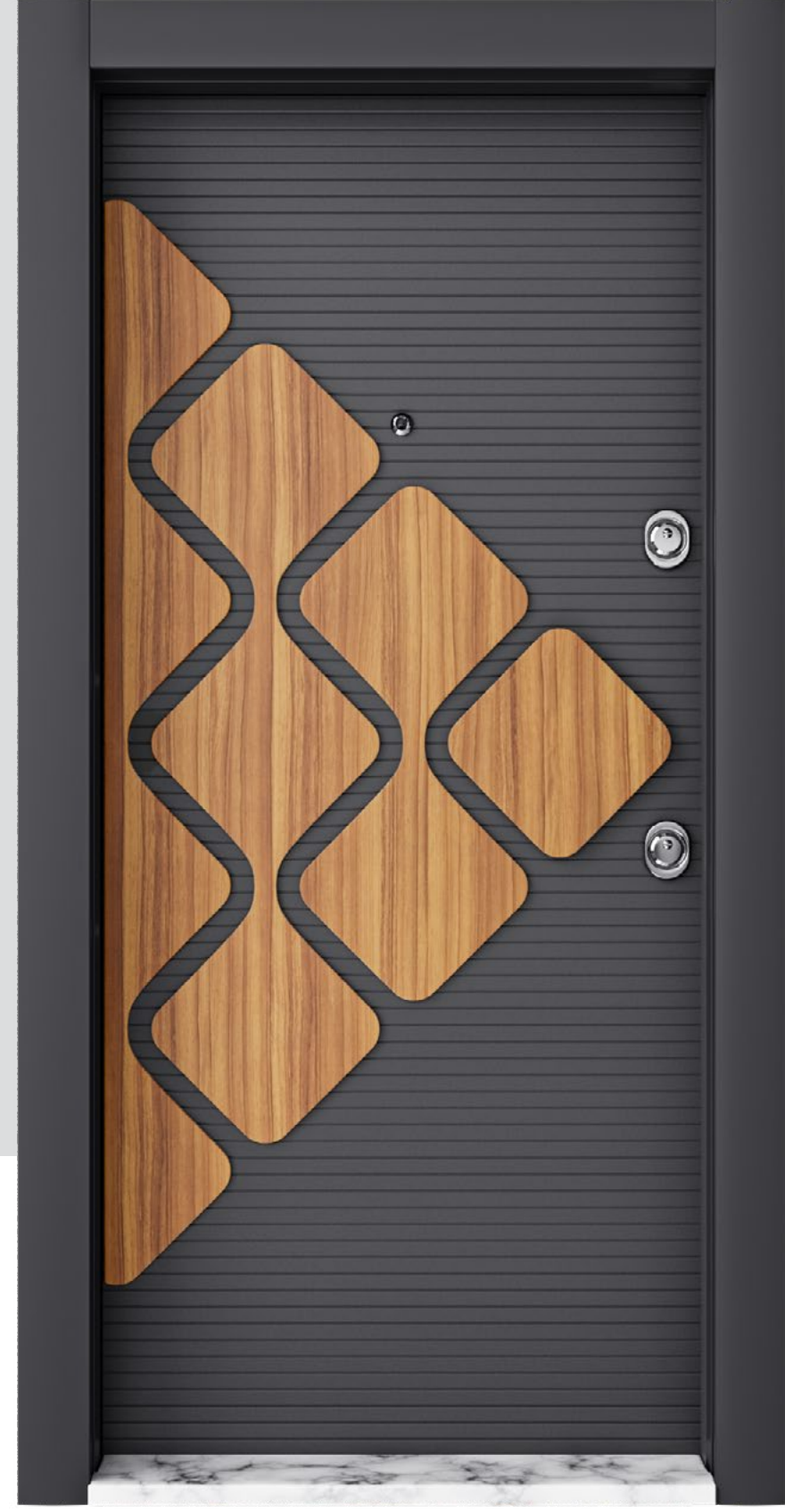

PVC Kabartma Serisi | PVC Embossed Doors

56 BUL



Ultralam Serisi | Ultralam Doors

59
BUL

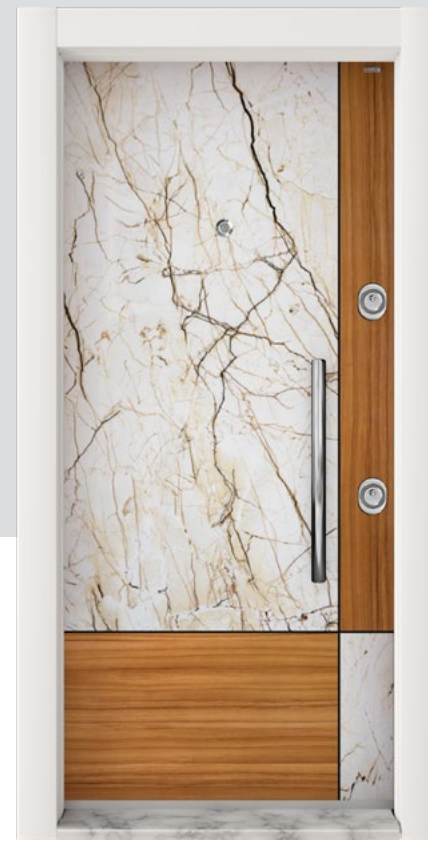

69
BUL



70
BUL



72
BUL



Ultralam Serisi | Ultralam Doors

81 BLX



Laminoks Serisi | Laminox Doors

88 BLX



89 BLX

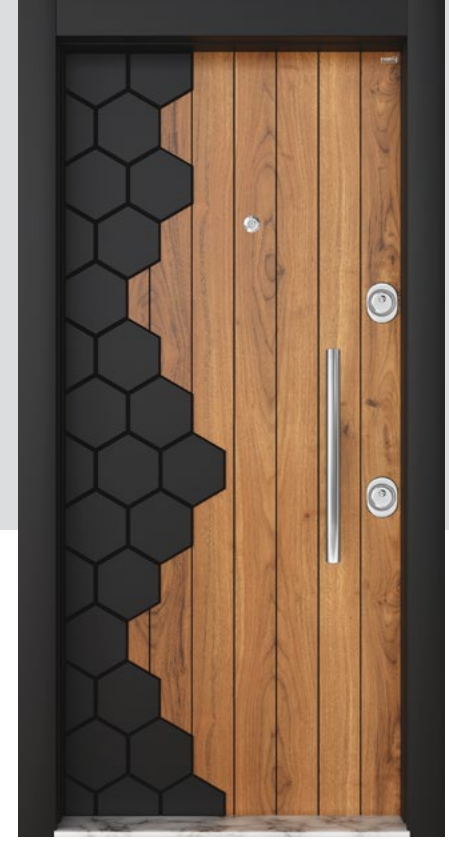

90 BLX



91 BLX



Laminoks Serisi | Laminox Doors



96
BLX



97
BLX



241
BLX



242
BLX

Laminoks Serisi | Laminok Doors



100
BLX



101
BLX

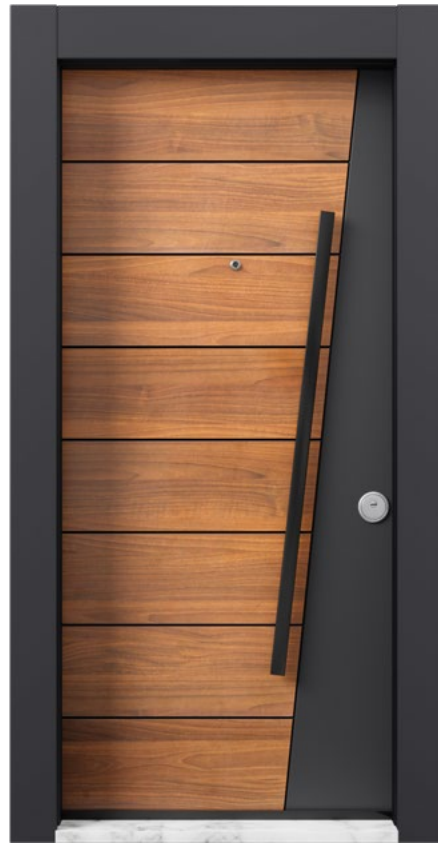

243
BLX



244
BLX

Laminoks Serisi | Laminok Doors



245
BLX



246
BLX



249
BLX



250
BLX

Laminoks Serisi | Laminoks Doors



247
BLX



248
BLX



251
BLX



252
BLX

Laminoks Serisi | Laminoks Doors

61 B P V



PVC Rustik | PVC Rustic

62 B P V



63 B P V

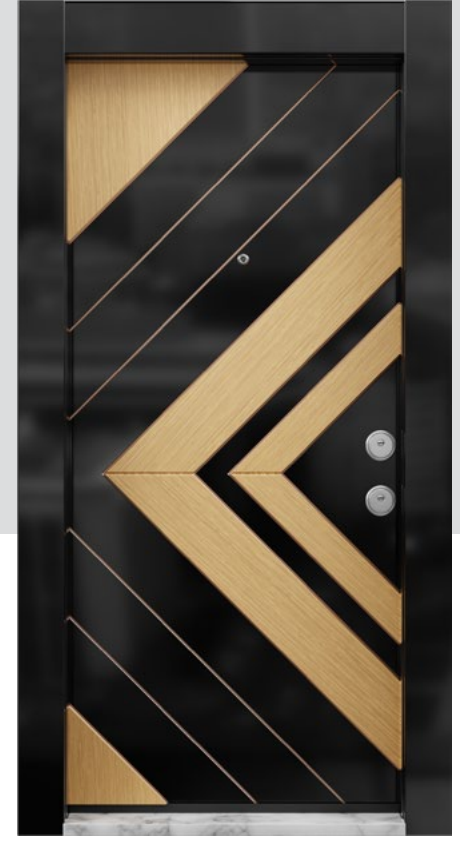

64 B P V

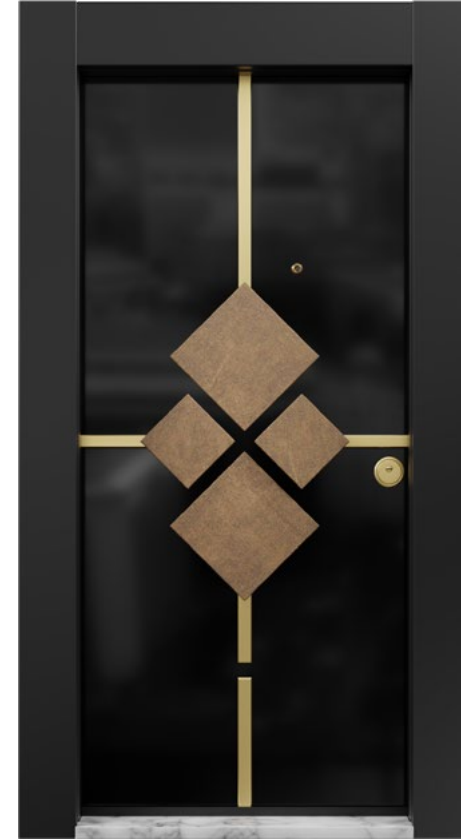

65 B P V



PVC Rustik | PVC Rustic

126 B S L

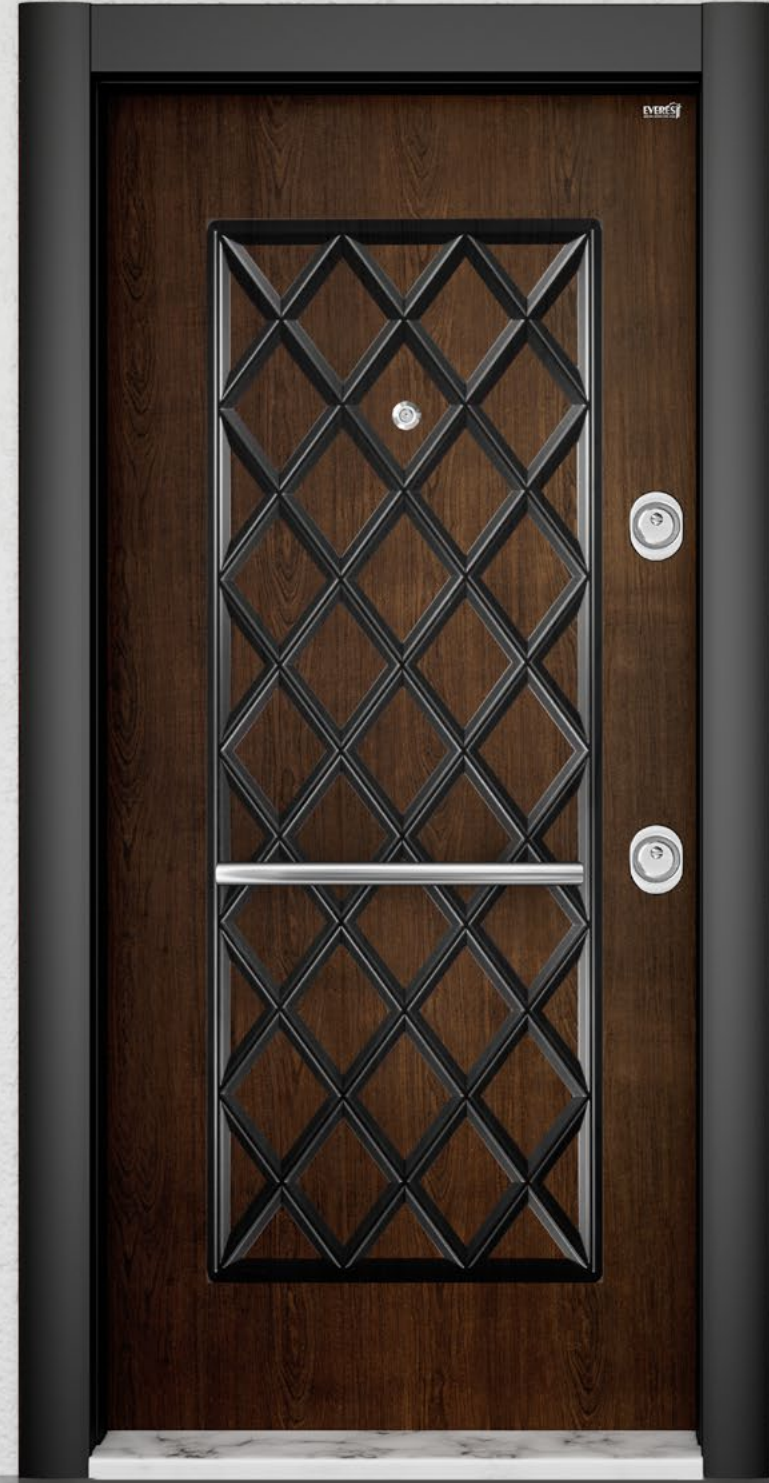

Silindir Serisi | Cylinder Doors

130 B S L

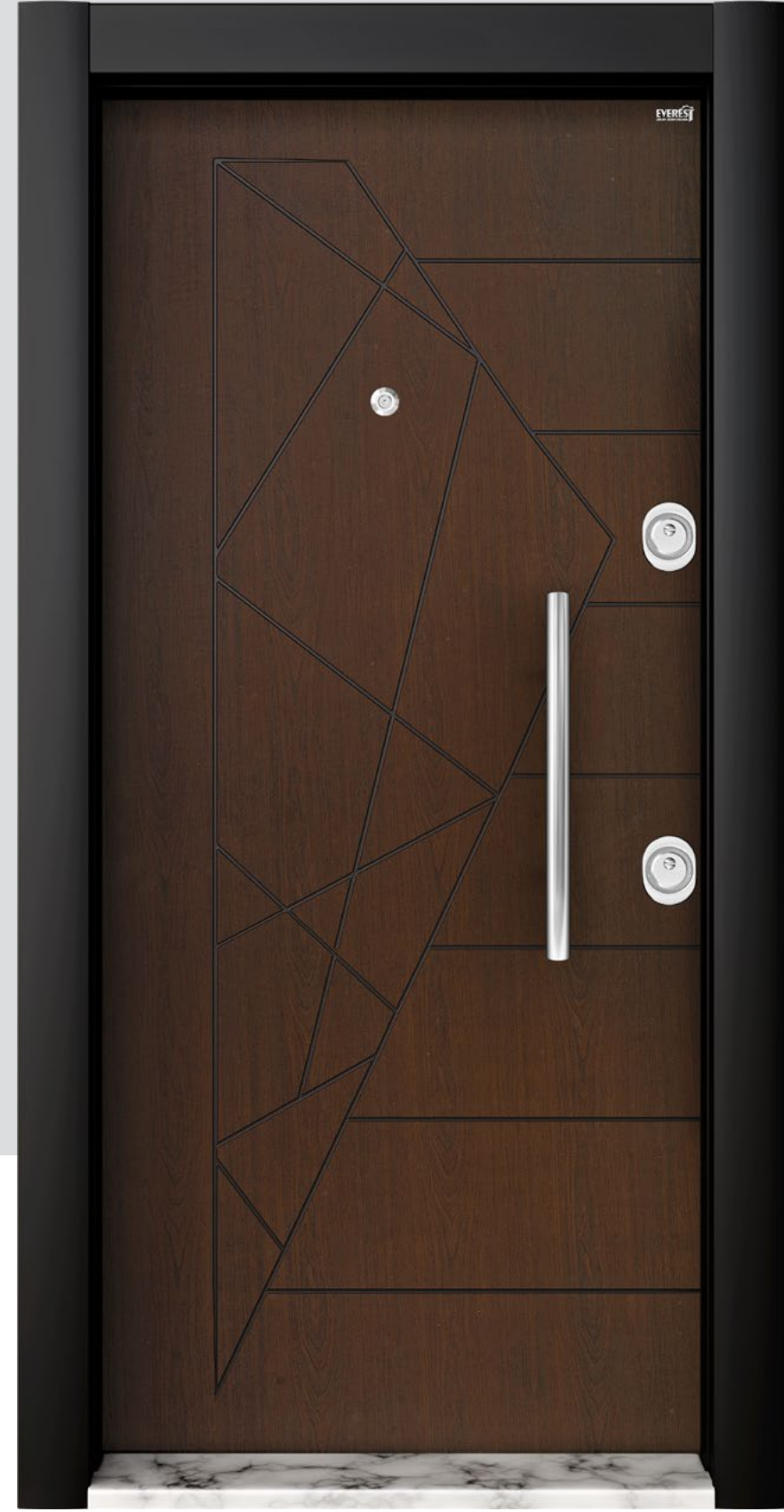

Silindir Serisi | Cylinder Doors

131
B M T

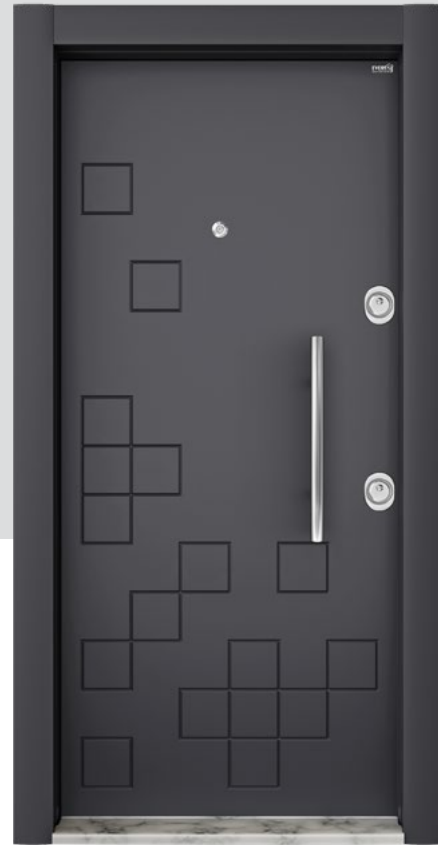

133
B M T



139
B M T



140
B M T



Sac Serisi | Full Metal Doors

134
B M T



138
B M T



141
B M T



142
B M T



Sac Serisi | Full Metal Doors



144
B M T



146
B M T



149
B M T



150
B M T

Sac Kabartma | Full Metal Emboss Doors



147
B M T



148
B M T



151
B M T



152
B M T

Sac Baskılı Kabartma | Full Metal Press Doors

136 BFR



Acil Çıkış Kapısı Serisi | Emergency Exit Doors

37 BFR



38 BFR



39 BFR



40 BFR



Acil Çıkış Kapısı Serisi | Emergency Exit Doors



41
BFR



43
BFR



44
BFR



42
BFR



45
BFR



46
BFR



147 B S F

148
B S F

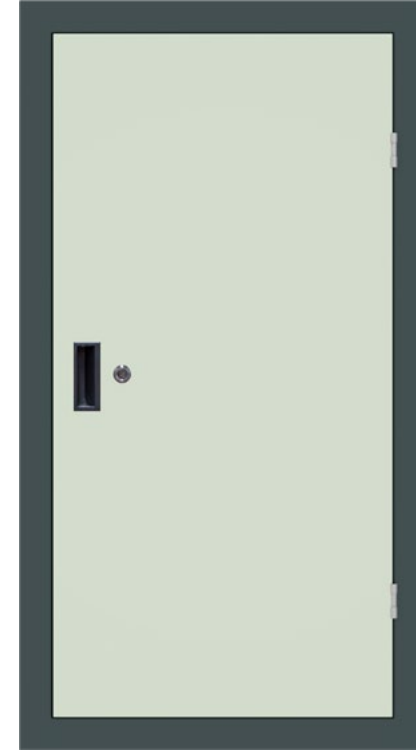

149
B S F

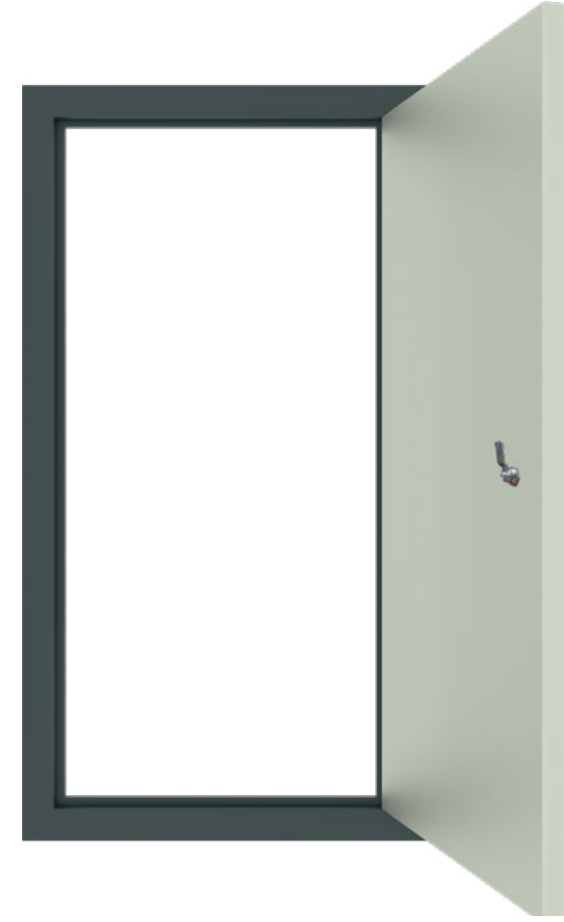

150
B S F



151
B S F

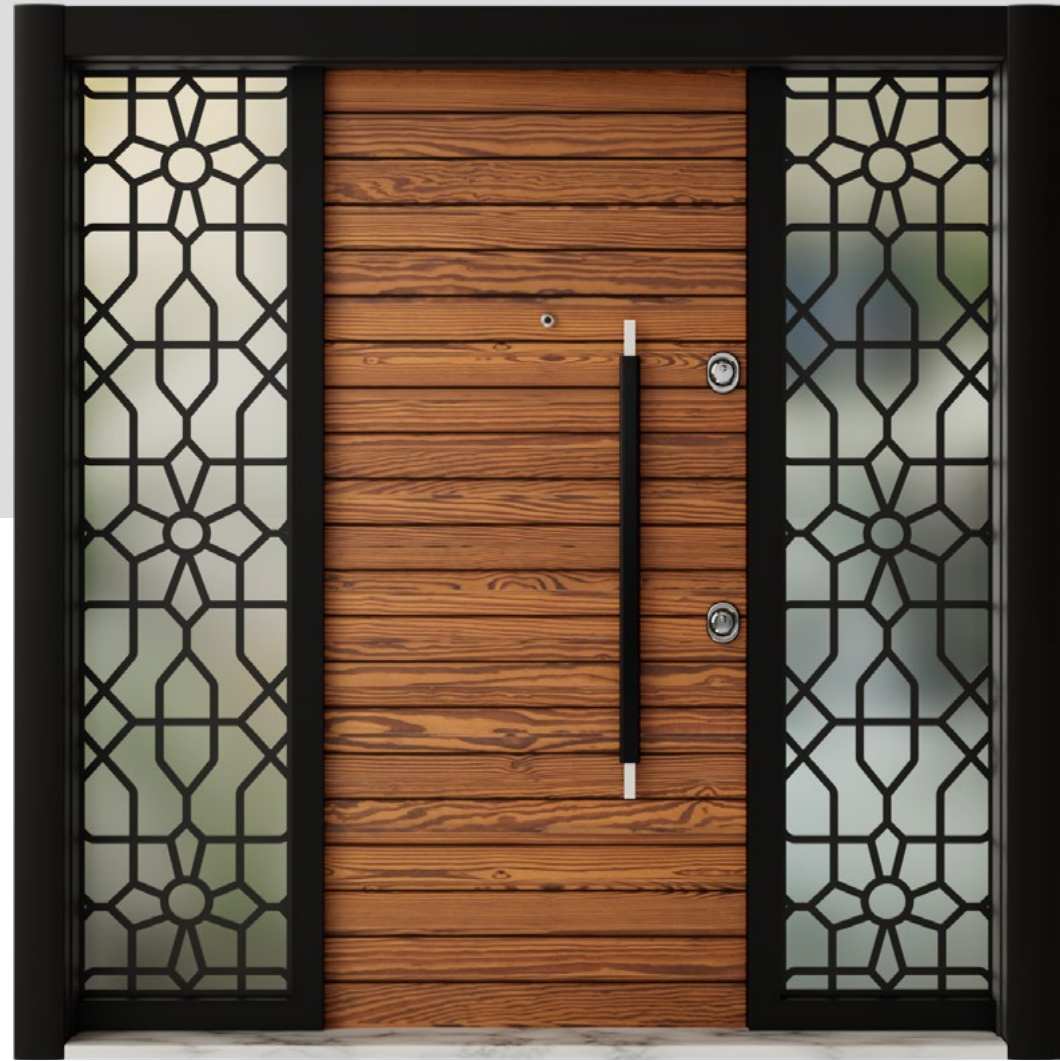

155
BVL



158
BVL

Villa Serisi | Main Entrance Doors



156
BVL

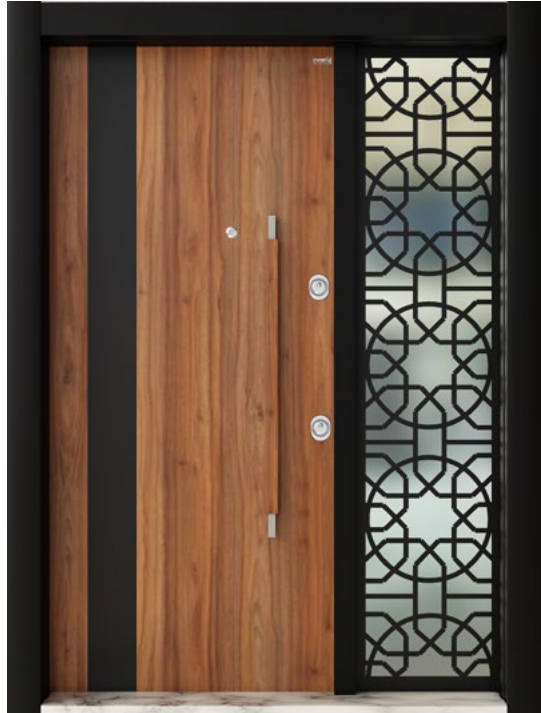

157
BVL

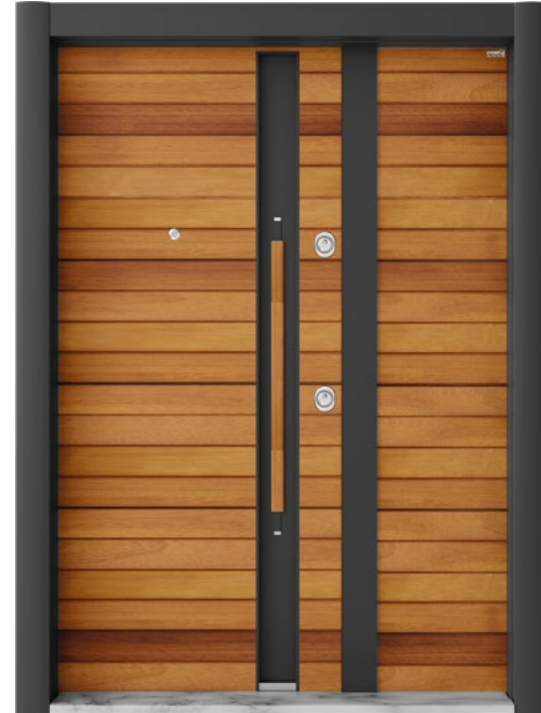

159
BVL



160
BVL

Villa Serisi | Main Entrance Doors

Ayarlı Kasa

Adjustable Frame

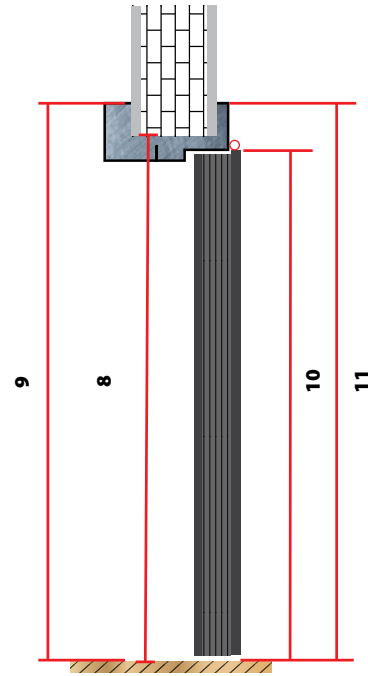

- | | | |
|--|--|--|
| 1 Kasa Boşluğu (En)
Leaf (Wing) Width
87-90-93-97-100-103 cm | 5 Dış Pervaz Bitimi
Exterior Moldings Border
104-107-110-114-117-120 cm | 9 Dış Üst Pervaz Bitimi
Overall Height (Exterior Moldings)
205-208-211-215-218-221 cm |
| 2 İç Pervaz Bitimi (En)
Interior Moldings Border (width)
104-107-110-114-117-120 cm | 6 Dış Pervaz Bitimi
Exterior Moldings
10 cm | 10 Kanat Boşluğu (Yükseklik)
Leaf (Wing) Height
197-200-203-207-210-213 cm |
| 3 İç Pervaz Genişliği
Interior Moldings Border
8,5 cm | 7 Duvar Kalınlığı
Wall Thickness
15-20 cm/ 20-25 cm/ 25-30 cm | 11 İç Üst Pervaz Bitimi
Overall Height (Interior Moldings)
205-208-211-215-218-221 cm |
| 4 Duvar Boşluk (En)
Wall Gap (Width)
94-97-100-104-107-110 cm | 8 Duvar Boşluk (Boy)
Wall Gap (height)
200-203-206-210-213-216 cm | |

İtalyan Kasa

Italian Frame

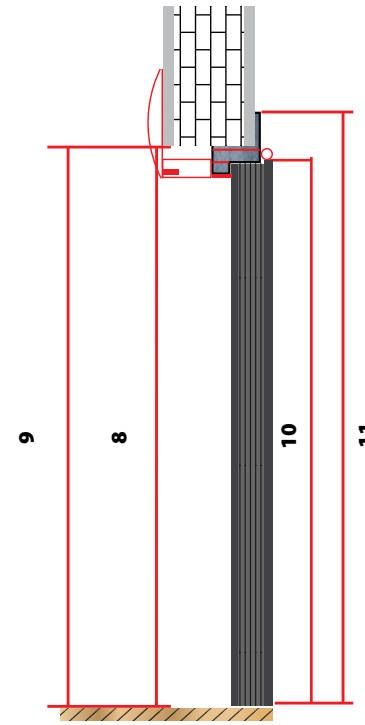

- | | | |
|--|--|--|
| 1 Kasa Boşluğu (En)
Leaf (Wing) Width
87-90-93-97-100-103 cm | 5 Dış Pervaz Bitimi
Exterior Moldings Border
95-98-101-105-108-111 cm | 9 Dış Üst Pervaz Bitimi
Overall Height (Exterior Moldings)
201-204-207-211-214-217 cm |
| 2 İç Pervaz Bitimi (En)
Interior Moldings Border (width)
104-107-110-114-117-120 cm | 6 Dış Pervaz Bitimi
Exterior Moldings
6 cm | 10 Kanat Boşluğu (Yükseklik)
Leaf (Wing) Height
197-200-203-207-210-213 cm |
| 3 İç Pervaz Genişliği
Interior Moldings Border
8,5 cm | 7 Duvar Kalınlığı
Wall Thickness
18-20 cm/ 20-22 cm/ 22-24 cm | 11 İç Üst Pervaz Bitimi
Overall Height (Interior Moldings)
205-208-211-215-218-221 cm |
| 4 Duvar Boşluk (En)
Wall Gap (Width)
97-100-104-107-110-113 cm | 8 Duvar Boşluk (Boy)
Wall Gap (height)
202-205-208-212-215-218 cm | 12 Dış Ahşap Pervaz
Exterior Wood Moldings
12 cm |

Corner Kasa

Corner Frame

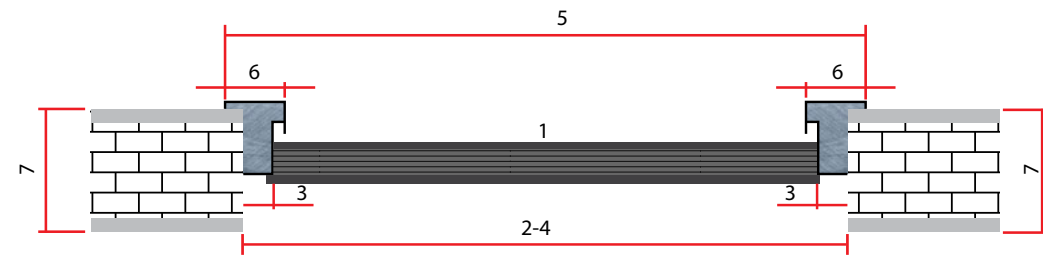
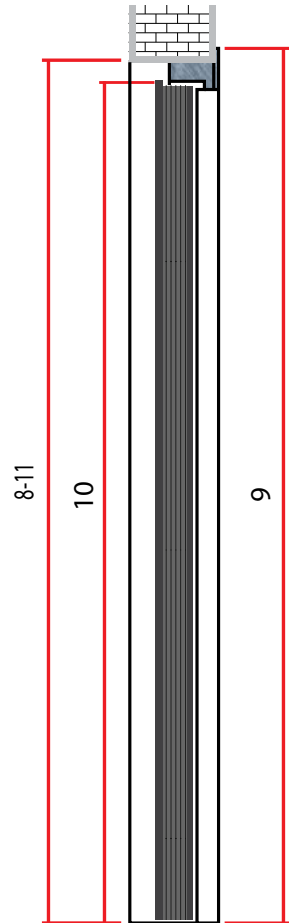

- | | | |
|--|--|--|
| 1 Kasa Boşluğu (En)
Leaf (Wing) Width
87-90-93-97-100-103 cm | 5 Dış Pervaz Bitimi
Exterior Moldings Border
103-106-109-113-116-119 cm | 9 Dış Üst Pervaz Bitimi
Overall Height (Exterior Moldings)
205-208-211-215-218-221 cm |
| 2 İç Pervaz Bitimi (En)
Interior Moldings Border (width)
95-98-101-105-108-111 cm | 6 Dış Pervaz Bitimi
Exterior Moldings
10 cm | 10 Kanat Boşluğu (Yükseklik)
Leaf (Wing) Height
197-200-203-207-210-213 cm |
| 3 İç Pervaz Genişliği
Interior Moldings Border
5 cm | 7 Duvar Kalınlığı
Wall Thickness
15-20-25-30 cm | 11 İç Üst Pervaz Bitimi
Overall Height (Interior Moldings)
201-204-207-211-214-217 cm |
| 4 Duvar Boşluk (En)
Wall Gap (Width)
97-100-104-107-110-113 cm | 8 Duvar Boşluk (Boy)
Wall Gap (height)
202-205-208-212-215-218 cm | |

Sol Kapı

Left Door

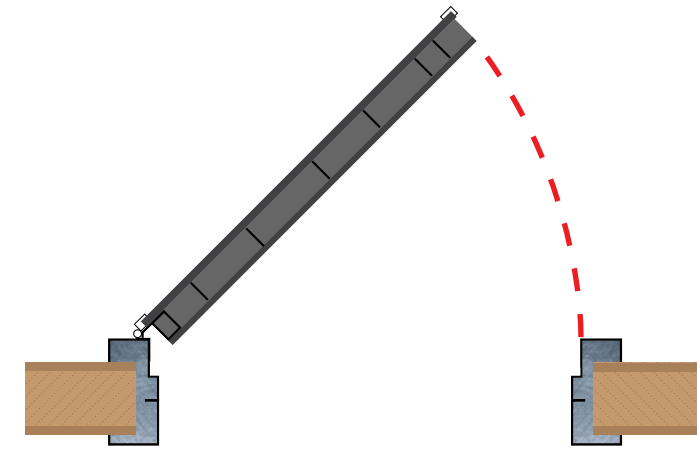

Sağ Kapı

Right Door

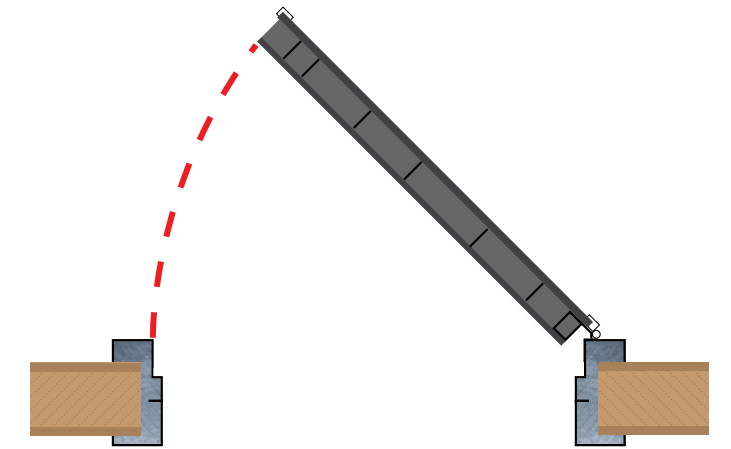

Teknik Detaylar | Technical Details

Kilit Sistemleri Lock Systems



**Merkezi
Kilit Sistemi**
Central
Lock System

**Yarı Merkezi
Kilit Sistemi**
Semi Central
Lock System

**Monoblok
Kilit Sistemi**
Monoblock
Lock System

**Kancalı
Kilit Sistemi**
Hook
Lock System

Teknik Detaylar | Technical Details

Kanat İç Görünümü Wing Interior View



- 1 Kanat İç Ahşabı
Internal Wood Of Leaf
- 2 Taş Yünü
Rockwool
- 3 Omurga Destek Sacları
Luxury Leaf Shutter
- 4 Çelik Ana Gövde
Steel Main Body
- 5 Kanat Dış Ahşabı
External Wood Of Leaf



**Gizli
Emniyet Kilidi**
Hidden Security Latch



Lüks Kanat Kesit
Luxury Part Of The Leaf



Dümbün
Peephole



WC Mandalı
WC Latch Lock



Mentese
Hinge

Kapı Kolları Door Handles

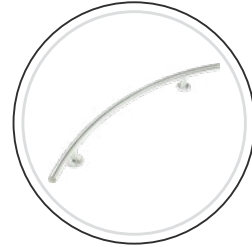

EV - ÇKL - 001
Pull Handle

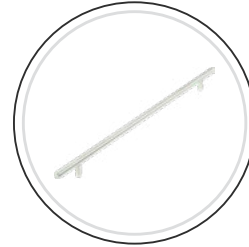

EV - ÇKL - 002
Pull Handle



EV - ÇKL - 003
Pull Handle

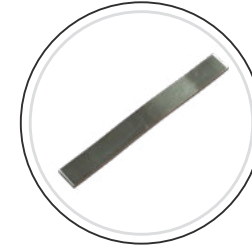

EV - ÇKL - 005
Pull Handle



EV - ÇKL - 007
Pull Handle

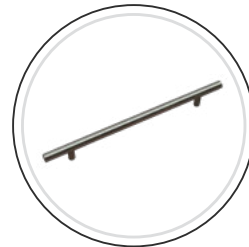

EV - ÇKL - 008
Pull Handle

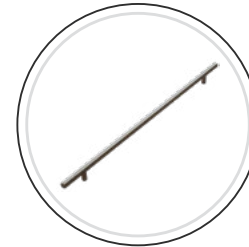

EV - ÇKL - 010
Pull Handle

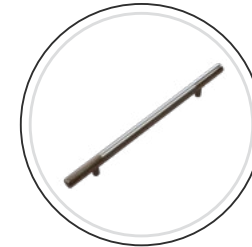

EV - ÇKL - 011
Pull Handle

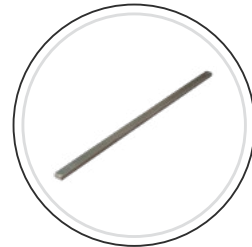

EV - ÇKL - 012
Pull Handle



EV - ÇKL - 013
Pull Handle



EV - ÇKL - 014
Pull Handle

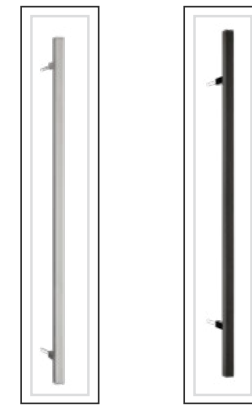

EV - ÇKL - 015 Pull Handle
EV - ÇKL - 016 Pull Handle



EV - RK - 013
Lever Handle



EV - RK - 014
Lever Handle



EV - RK - 015
Lever Handle



EV - RK - 016
Lever Handle

Kilit Sistemi Lock Systems

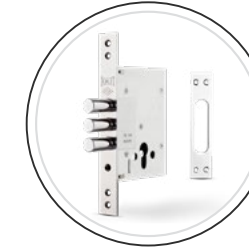

EV - KLT - 001
Monoblok

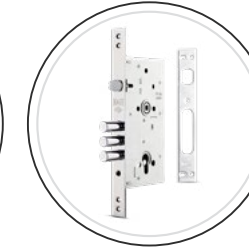

EV - KLT - 002
Kancalı

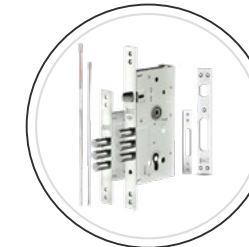

EV - KLT - 003
Yarı Merkezi
Half Central

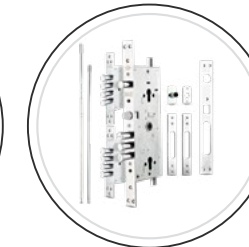

EV - KLT - 004
Merkezi Kilit
Central Lock



EV - A - 001
Sistem Barel



EV - A - 002
German Barel

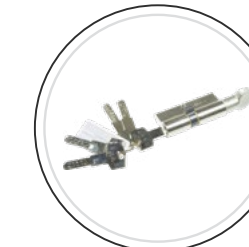

EV - A - 003
Bilyalı Mandallı Barel



EV - A - 004
Bilyalı Barel



EV - A - 005
German Mandallı Barel

Diğer Aksesuarlar Other Accessories



EV - DA - 001
Door Knocker



EV - DA - 002
Door Knocker



EV - DA - 003
Door Knocker



EV - DA - 004
Door Knocker



EV - DA - 005
Door Viewer (Big)



EV - DA - 006
Door Viewer (Small)